

freud.

**Cutterheads and
Brazeed Cutters
Teste Portacoltelli e Frese
Saldobrasate**

Catalogue - Catalogo

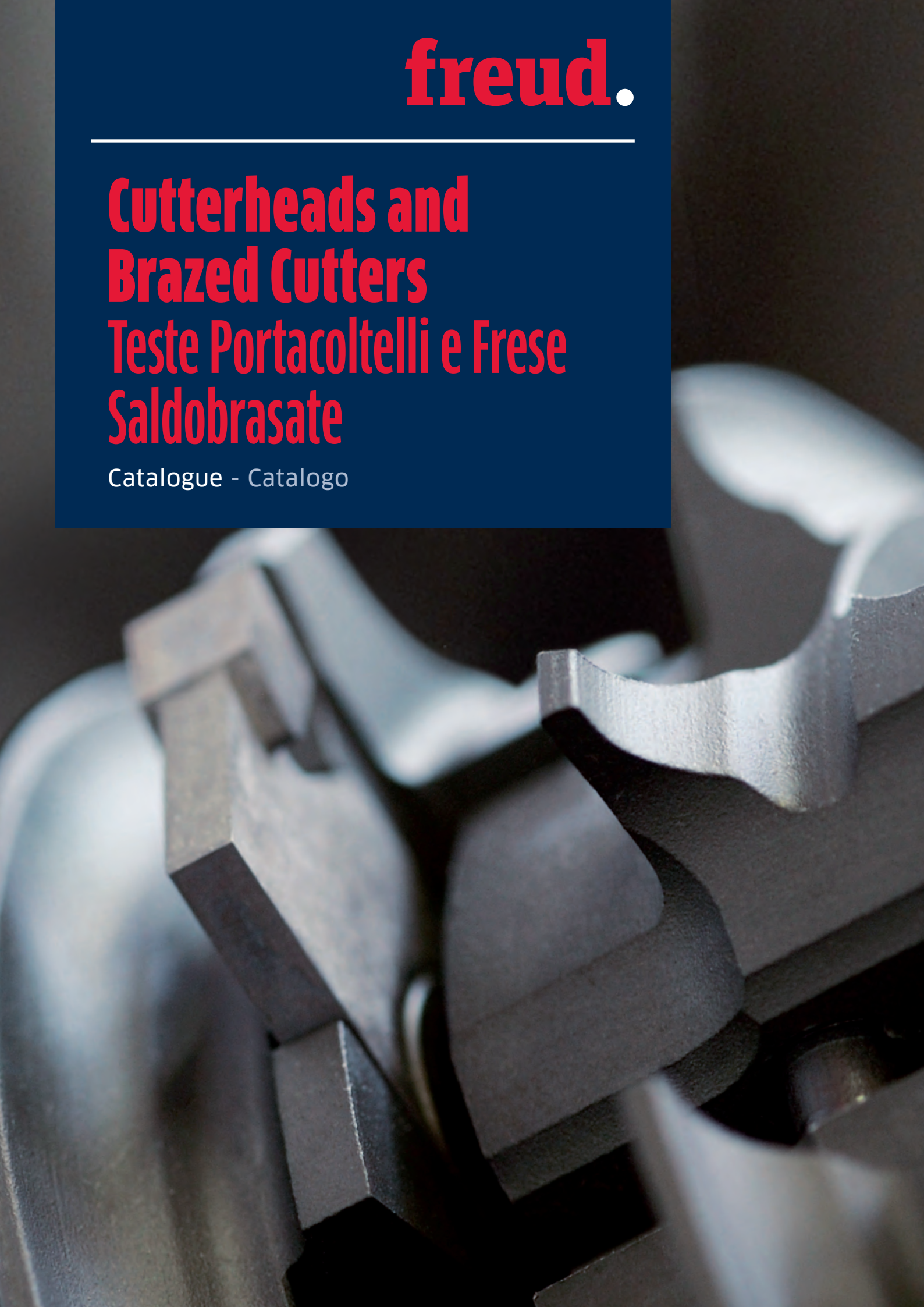

TG79MG Z = 2

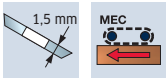

Cutterheads sets for panelling and flooring Gruppi di teste per perline e parchetti

The cutterhead sets come complete with bevelling inserts. The AG3-AI3-AM3-AO3 spare cutterheads are supplied without inserts and screws, which should be ordered separately.

I gruppi sono disponibili a magazzino, completi di inserti. Le teste di ricambio AG3-AI3-AM3-AO3 vengono fornite senza inserti e relative viti, i quali andranno ordinati a parte.

Profile Profilo	Tongue set Gruppo per maschio	SAP SAP	Groove set Gruppo per femmina	SAP SAP
1	TG79MG 002	F03FC20305	TG79MG 001	F03FC20304
2	TG79MG 003	F03FC20306	TG79MG 001	F03FC20304
3	TG79MG 006	F03FC20309	TG79MG 004	F03FC20307
4	TG79MG 025	F03FC20320	TG79MG 020	F03FC20315
5	TG79MG 007	F03FC20310	TG79MG 005	F03FC20308
6	TG79MG 026	F03FC20321	TG79MG 021	F03FC20316
7	TG79MG 027	F03FC20322	TG79MG 022	F03FC20317
8	TG79MG 028	F03FC20323	TG79MG 023	F03FC20318
9	TG79MG 029	F03FC20324	TG79MG 024	F03FC20319
10	TG79MG 010	F03FC20313	TG79MG 008	F03FC20311
11	TG79MG 035	F03FC20330	TG79MG 030	F03FC20325
12	TG79MG 011	F03FC20314	TG79MG 009	F03FC20312
13	TG79MG 036	F03FC20331	TG79MG 031	F03FC20326
14	TG79MG 037	F03FC20332	TG79MG 032	F03FC20327
15	TG79MG 038	F03FC20333	TG79MG 033	F03FC20328
16	TG79MG 039	F03FC20334	TG79MG 034	F03FC20329

Tools for TG79MG sets - Utensili per gruppi TG79MG

D mm	B mm	d mm	Z	R	Max RPM 1/min.	Code Codice	SAP SAP
125	20	50	2	2	9.000	TG79M AA3	F03FC20286
125	20	50	2	2	9.000	TG79M AB3	F03FC20287
143	20	50	2	2	9.000	TG79M AC3	F03FC20288
128	8	50	2		9.000	TG79M AD3	F03FC20289
143	20	50	2	4	9.000	TG79M AE3	F03FC20290
144	20	50	2	4	9.000	TG79M AF3	F03FC20291
125	20	50		4	9.000	TG79M AG3	F03FC20292
125	20	50		4	9.000	TG79M AI3	F03FC20294
143	20	50		4	9.000	TG79M AM3	F03FC20296
143	20	50		4	9.000	TG79M AO3	F03FC20298

The above codes are intended without sleeve, which should be ordered separately.

I codici delle tabelle relative ai gruppi sono da considerarsi esclusa la bussola, la quale andrà ordinata a parte.

Sleeves for fence side spindle Bussolle per albero destro

Dimensions Dimensioni mm	Sleeve code Codice bussola	SAP SAP
Ø50 x 110 x 30	BF10MD AA9	F03FC00616
Ø50 x 110 x 32	BF10MD AL9	F03FC24533
Ø50 x 110 x 35	BF10MD AB9	F03FC00617
Ø50 x 110 x 40	BF10MD AC9	F03FC00618

Sleeves for off side spindle Bussolle per albero sinistro

Dimensions Dimensioni mm	Sleeve code Codice bussola	SAP SAP
Ø50 x 110 x 30	BF10MS AA9	F03FC00661
Ø50 x 110 x 32	BF10MS AL9	F03FC24538
Ø50 x 110 x 35	BF10MS AB9	F03FC00662
Ø50 x 110 x 40	BF10MS AC9	F03FC00663

	Dimensions Dimensioni mm	Code Codice	SAP SAP
AA3	20 x 12 x 1,5	CG01MDA310	F03FH02727
	16	CN01M DA9	F03FC01251
	M8 x 16	VT03M AA9	F03FA04435
	40 x 16 x 4	IG04MDAA305	F03FH03409
	M6 x 14,5	VT16M AA9	F03FA04476
AB3	20 x 12 x 1,5	CG01MDA310	F03FH02727
	16	CN01M DA9	F03FC01251
	M8 x 16	VT03M AA9	F03FA04435
	40 x 16 x 4	IG04MSAA305	F03FH02994
	M6 x 14,5	VT16M AA9	F03FA04476
AC3	20 x 12 x 1,5	CG01MDA310	F03FH02727
	16	CN01M DA9	F03FC01251
	M8 x 16	VT03M AA9	F03FA04435
	22,86 x 2,5	RG02MAA305	F03FH03041
	M5 x 8	VT05M AA9	F03FA04444
AD3	7,5 x 12 x 1,5	CG01MOB310	F03FC23814
	14 x 7,2 x 8	CN09M AT9	F03FC01294
	M5 x 19	VT11M AA9	F03FA04468
AE3 - AF3	20 x 12 x 1,5	CG01MDA310	F03FH02727
	16	CN01M DA9	F03FC01251
	M8 x 16	VT03M AA9	F03FA04435
	22,86 x 2,5	RG02MAA305	F03FH03041
	M5 x 8	VT05M AA9	F03FA04444
AG3 - AI3 - AM3 - AO3	22 x 16 x 5 45°	IG51MBA305	F03FH03022
	M6 x 14,5	VT16M AA9	F03FA04476
	22 x 16 x 5 45°	IG51MBA305	F03FH03022
	22 x 16 x 5 R=1,5	IG52MAB305	F03FH03023
	22 x 16 x 5 R=2	IG52MAC305	F03FH03024
22 x 16 x 5 R=3	IG52MAE305	F03FH03025	
M6 x 14,5	VT16M AA9	F03FA04476	
25,5 x 16 x 9 R3	IG33MAA305	F03FH03019	
25,5 x 16 x 9 R5	IG33MAB305	F03FH03020	
25,5 x 16 x 9 45°	IG33MAD305	F03FH03021	
M6 x 15,5	VT16M AD9	F03FC20657	

PROFILE / PROFILO 1

Cutterhead set / Gruppo
TG79MG 002

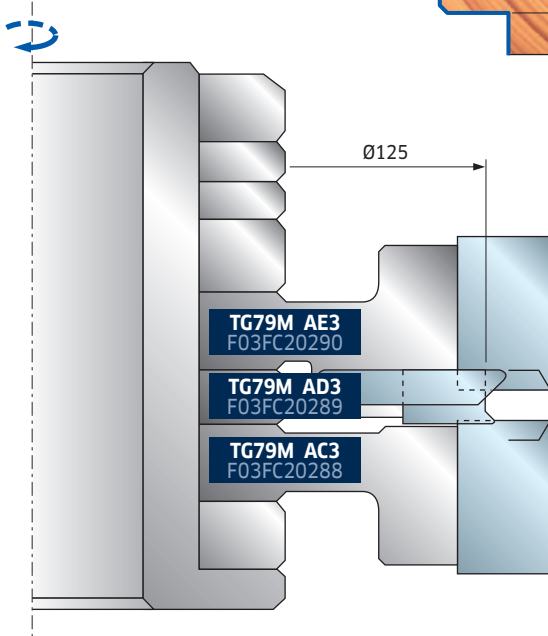

Cutterhead set / Gruppo
TG79MG 001

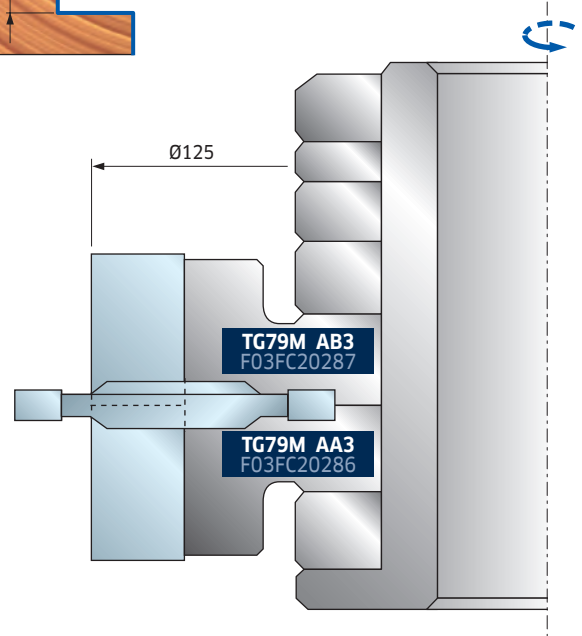

PROFILE / PROFILO 2

Cutterhead set / Gruppo
TG79MG 003

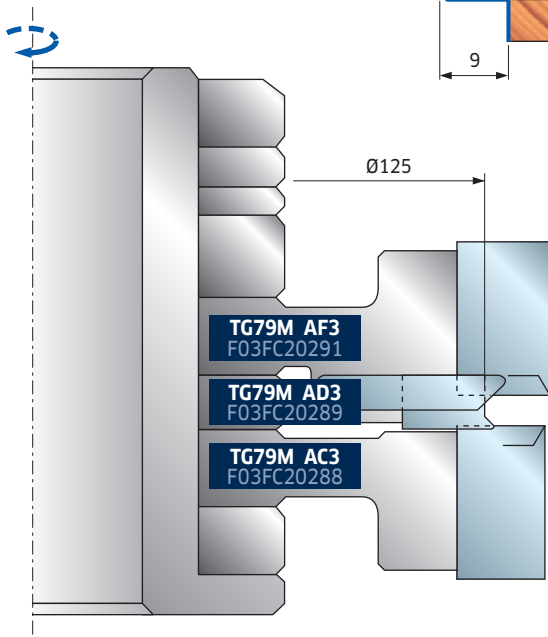

Cutterhead set / Gruppo
TG79MG 001

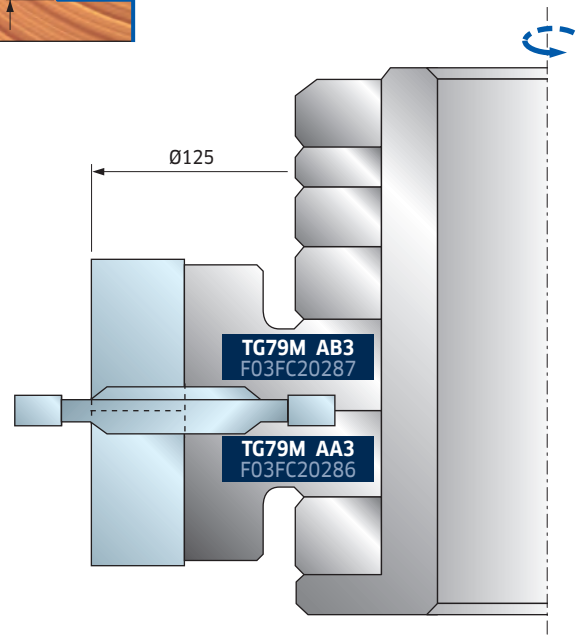

PROFILE / PROFILO 3

Cutterhead set / Gruppo TG79MG 006

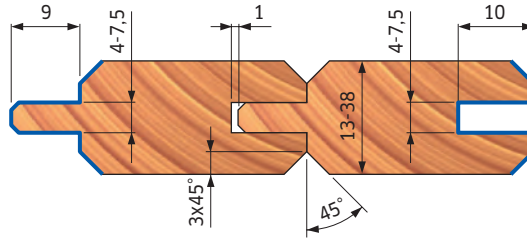

Cutterhead set / Gruppo TG79MG 004

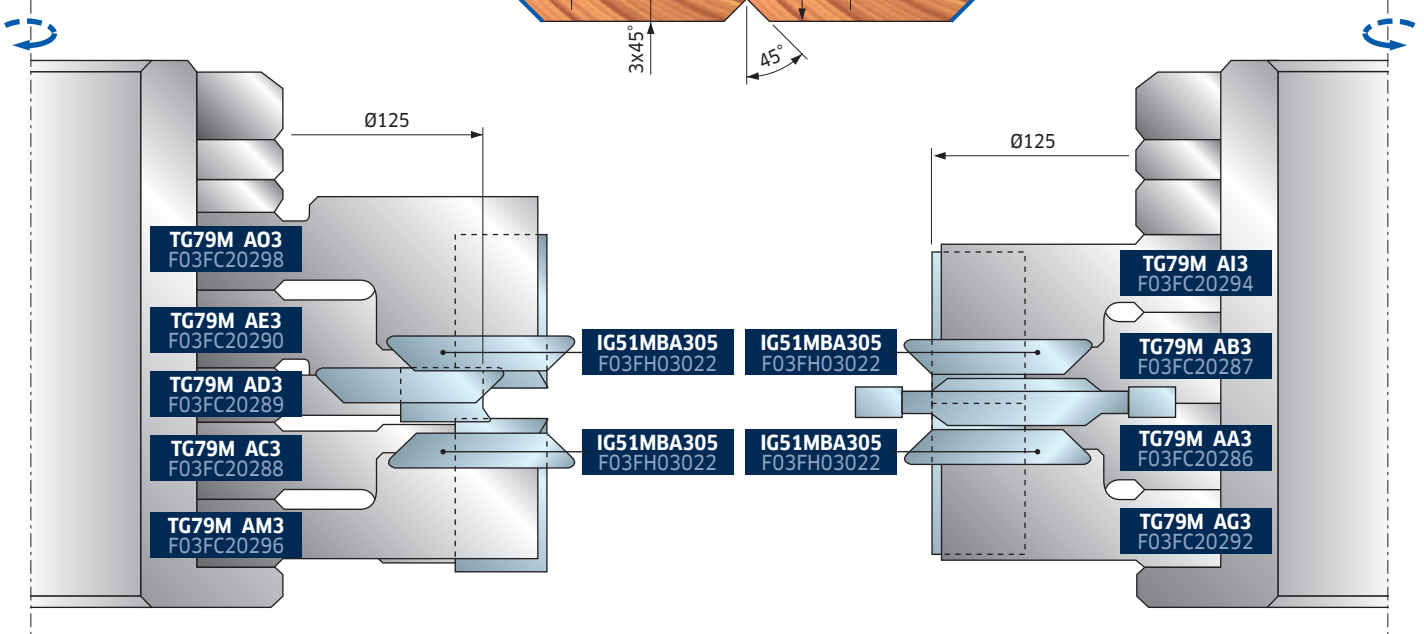

PROFILE / PROFILO 4

Cutterhead set / Gruppo TG79MG 025

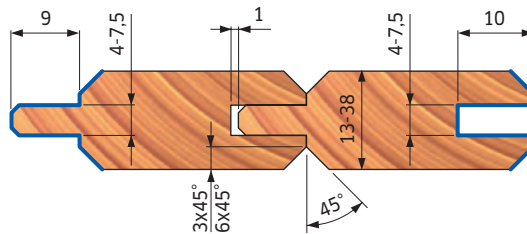

Cutterhead set / Gruppo TG79MG 020

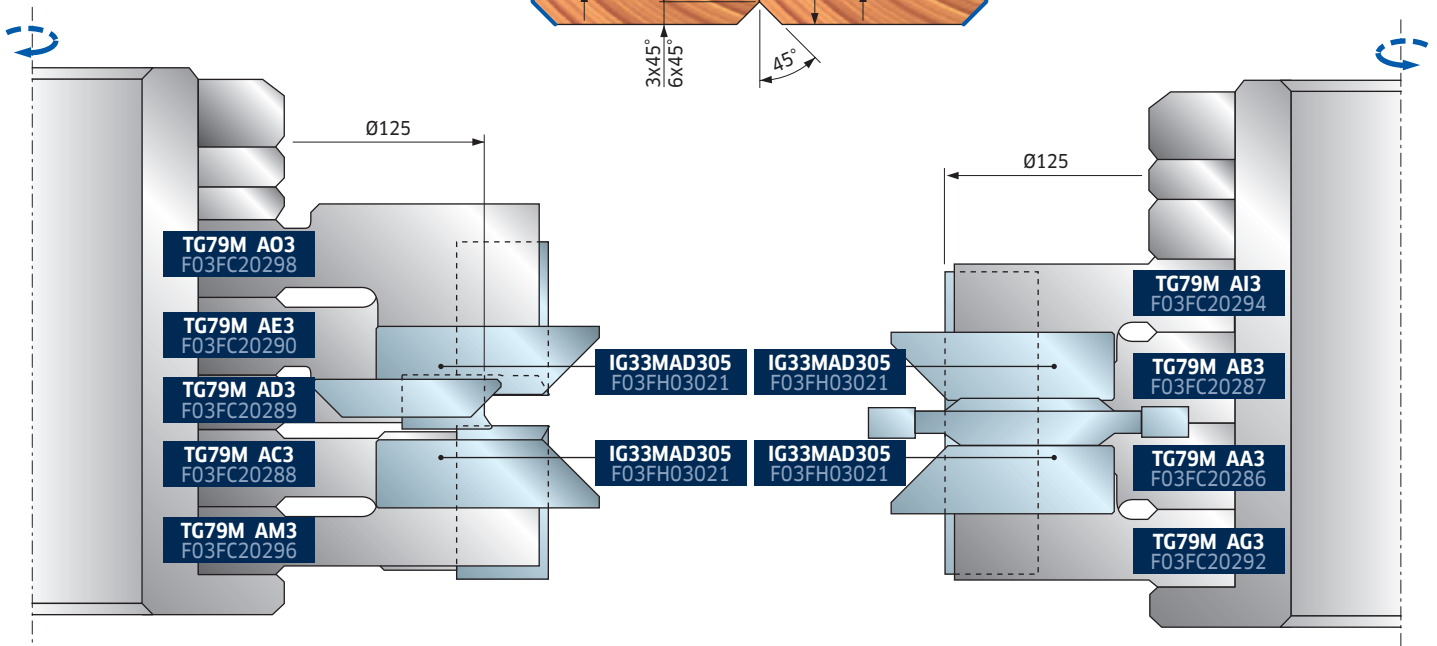

PROFILE / PROFILO 5

Cutterhead set / Gruppo
TG79MG 007

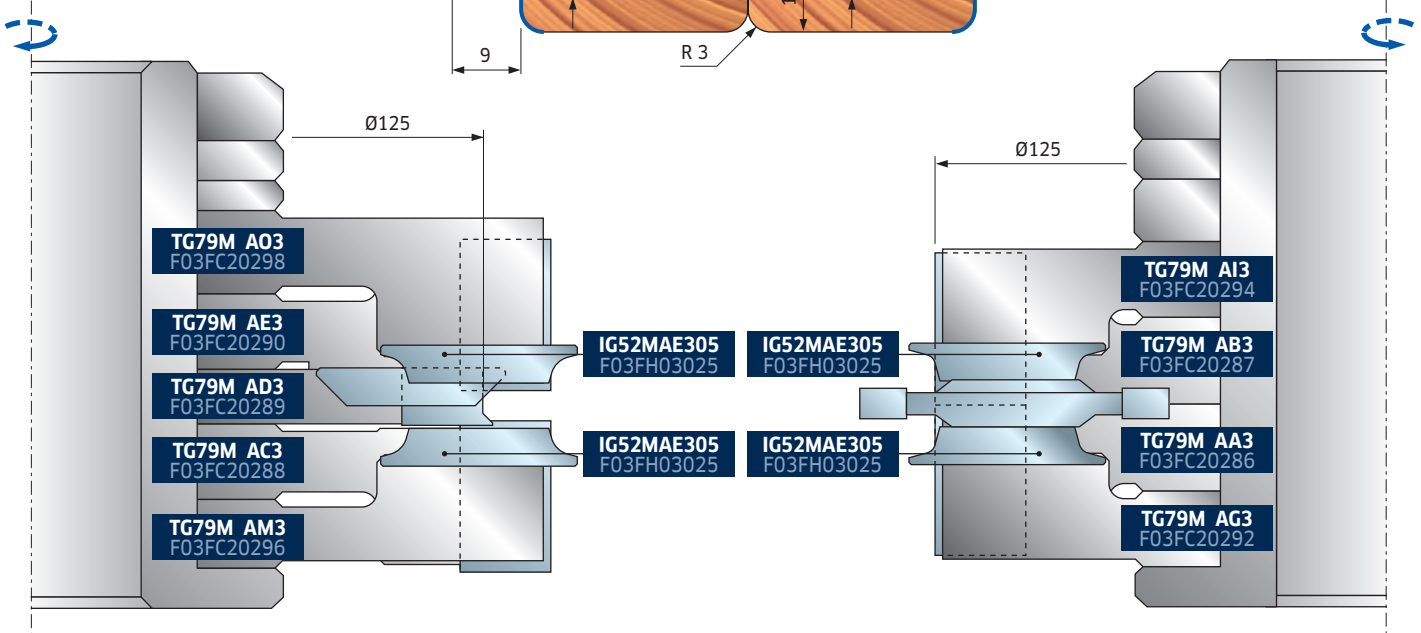

PROFILE / PROFILO 6

Cutterhead set / Gruppo
TG79MG 026

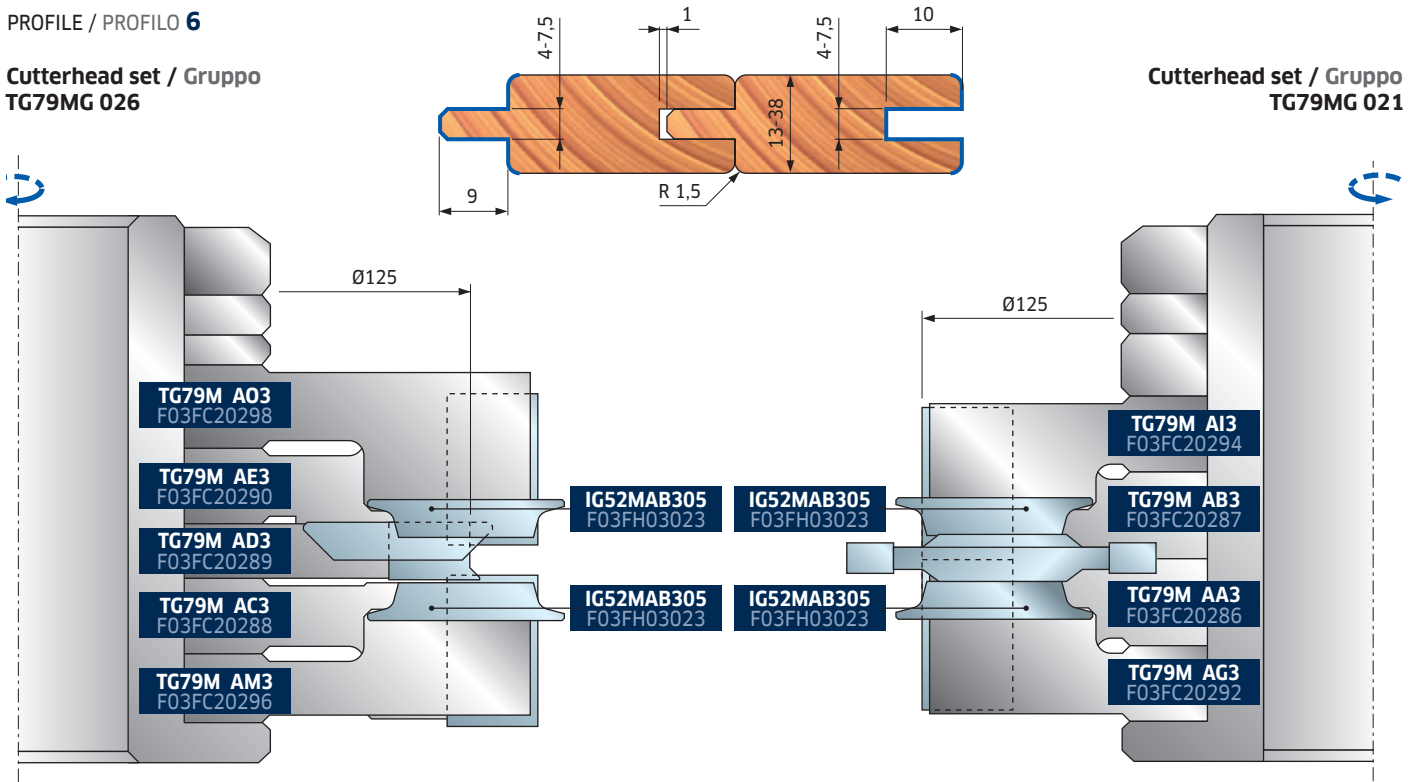

PROFILE / PROFILO 7

Cutterhead set / Gruppo TG79MG 027

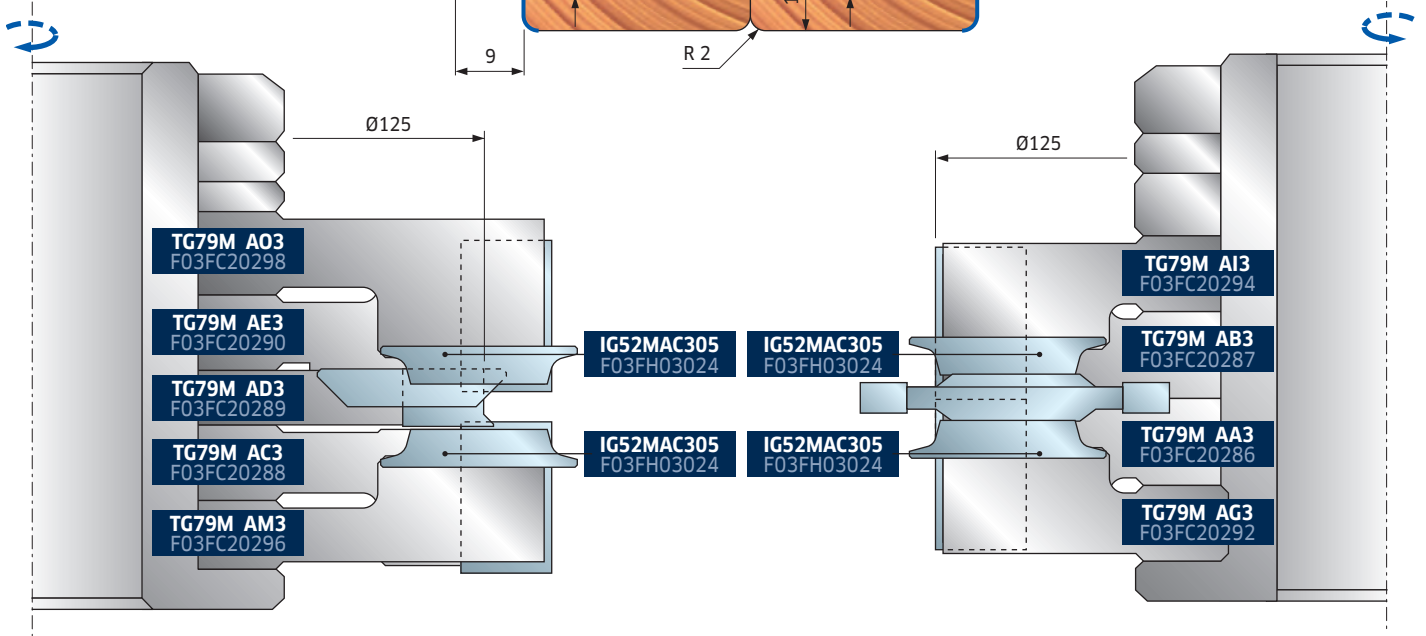

PROFILE / PROFILO 8

Cutterhead set / Gruppo TG79MG 028

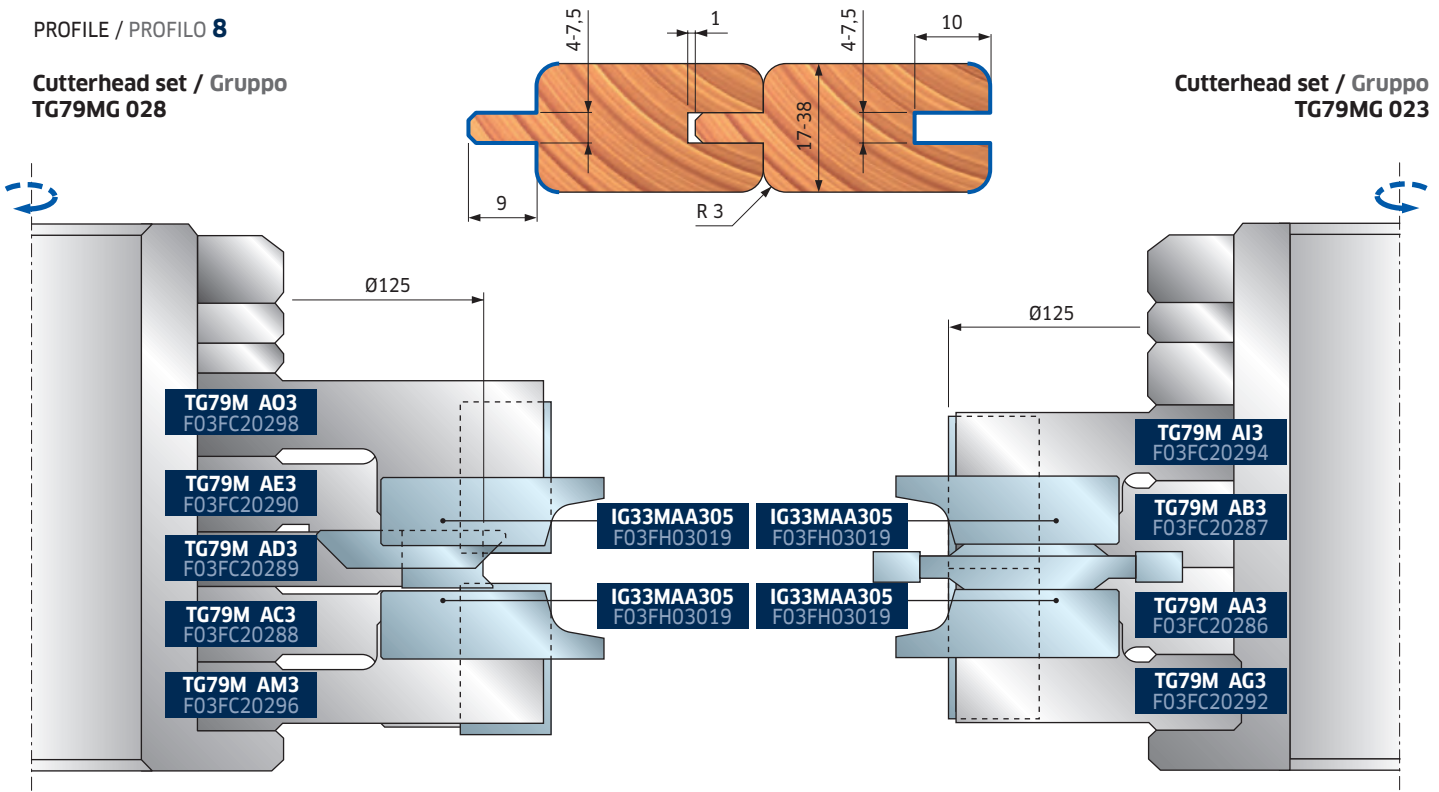

PROFILE / PROFILO 9

Cutterhead set / Gruppo
TG79MG 029

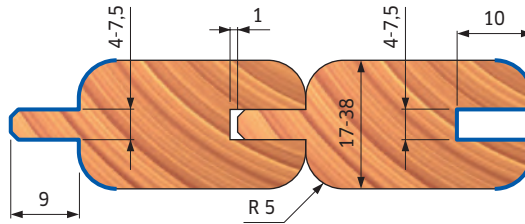

Cutterhead set / Gruppo
TG79MG 024

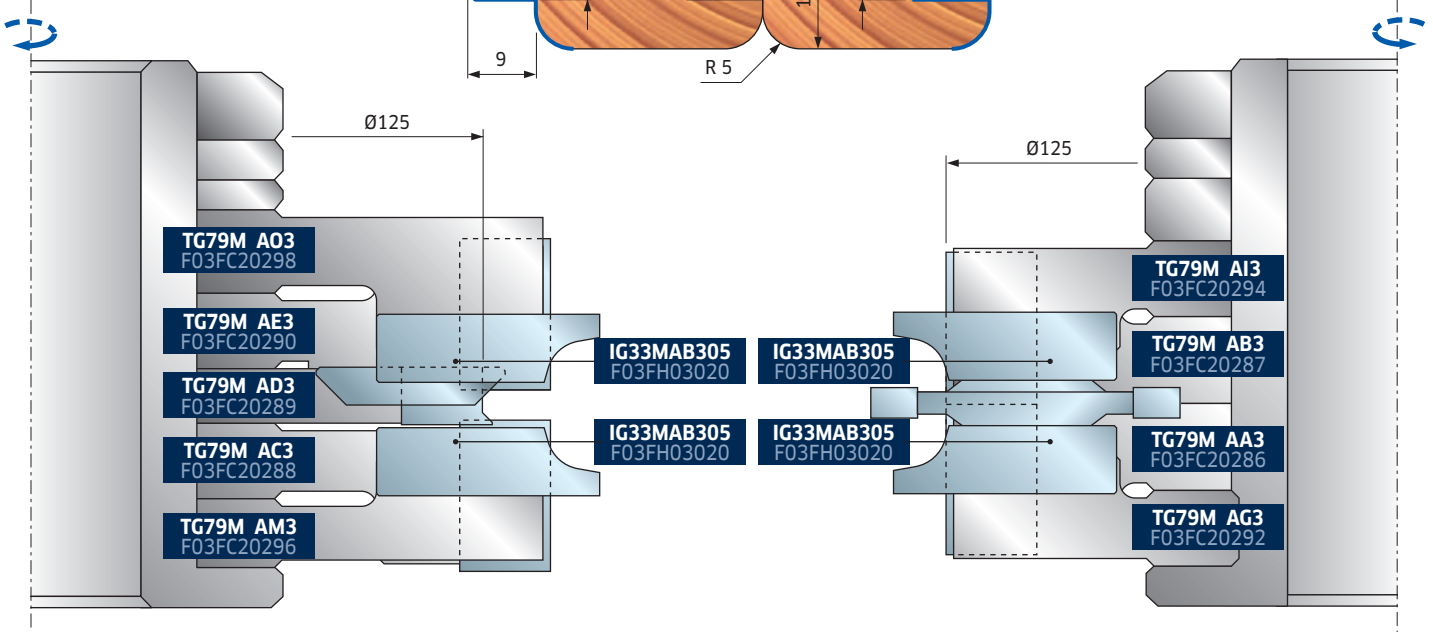

PROFILE / PROFILO 10

Cutterhead set / Gruppo
TG79MG 010

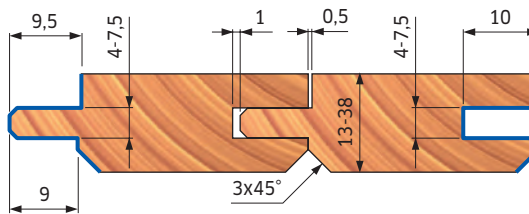

Cutterhead set / Gruppo
TG79MG 008

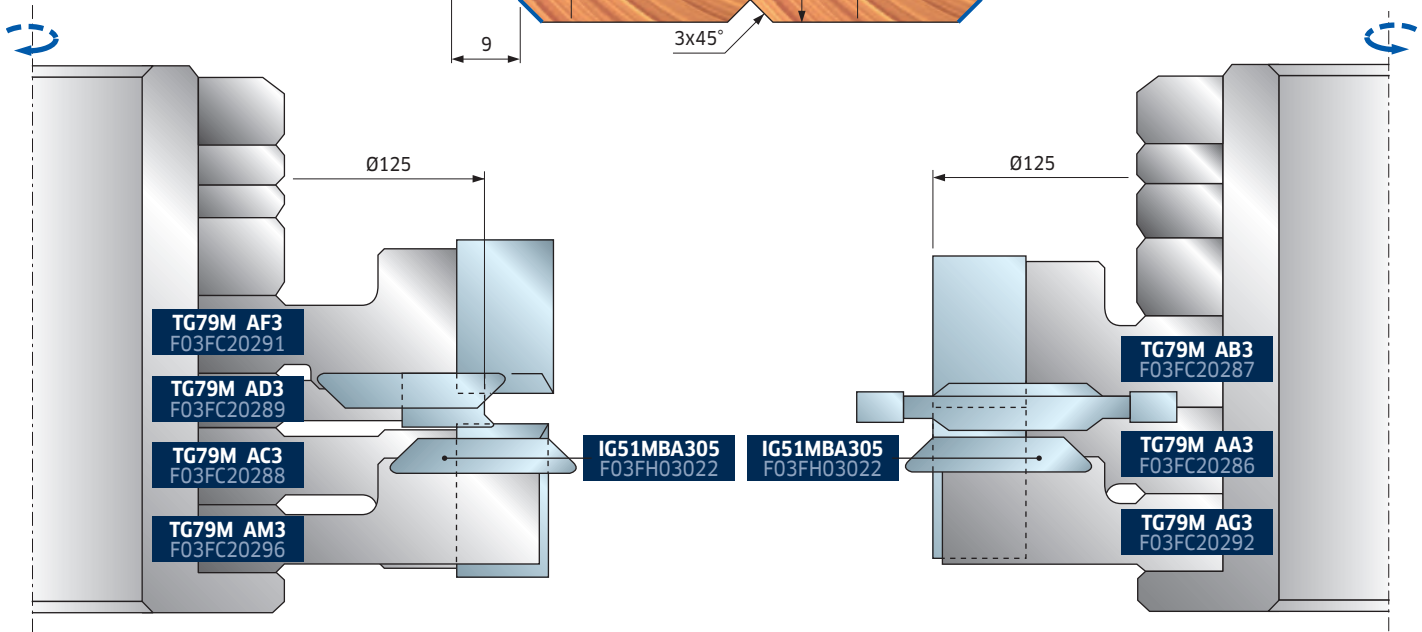

PROFILE / PROFILO 11

Cutterhead set / Gruppo
TG79MG 035

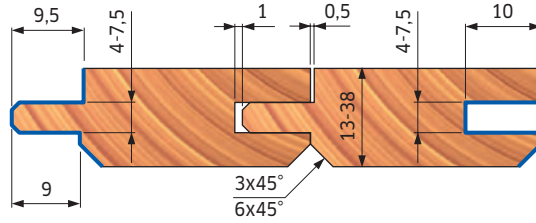

Cutterhead set / Gruppo
TG79MG 030

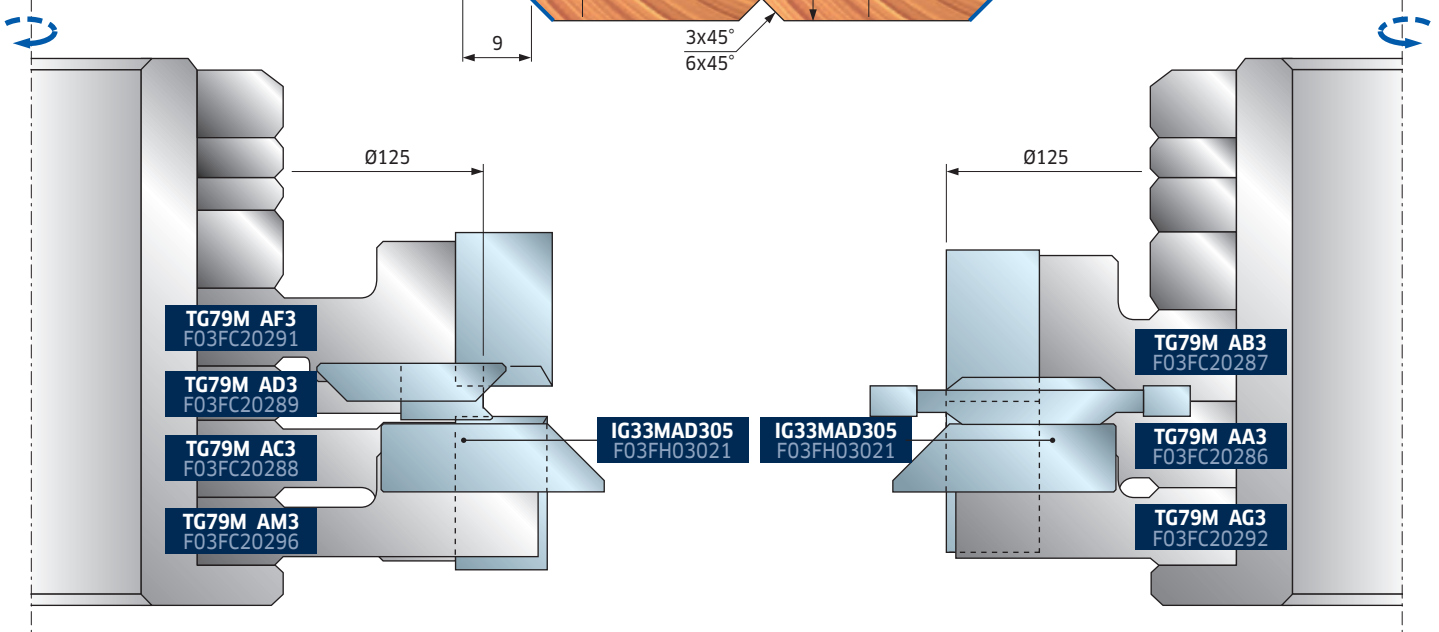

PROFILE / PROFILO 12

Cutterhead set / Gruppo
TG79MG 011

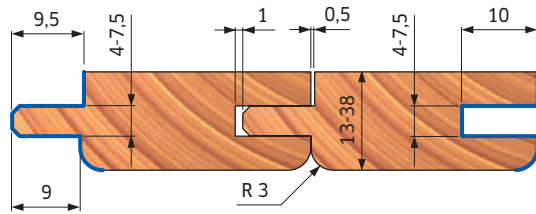

Cutterhead set / Gruppo
TG79MG 009

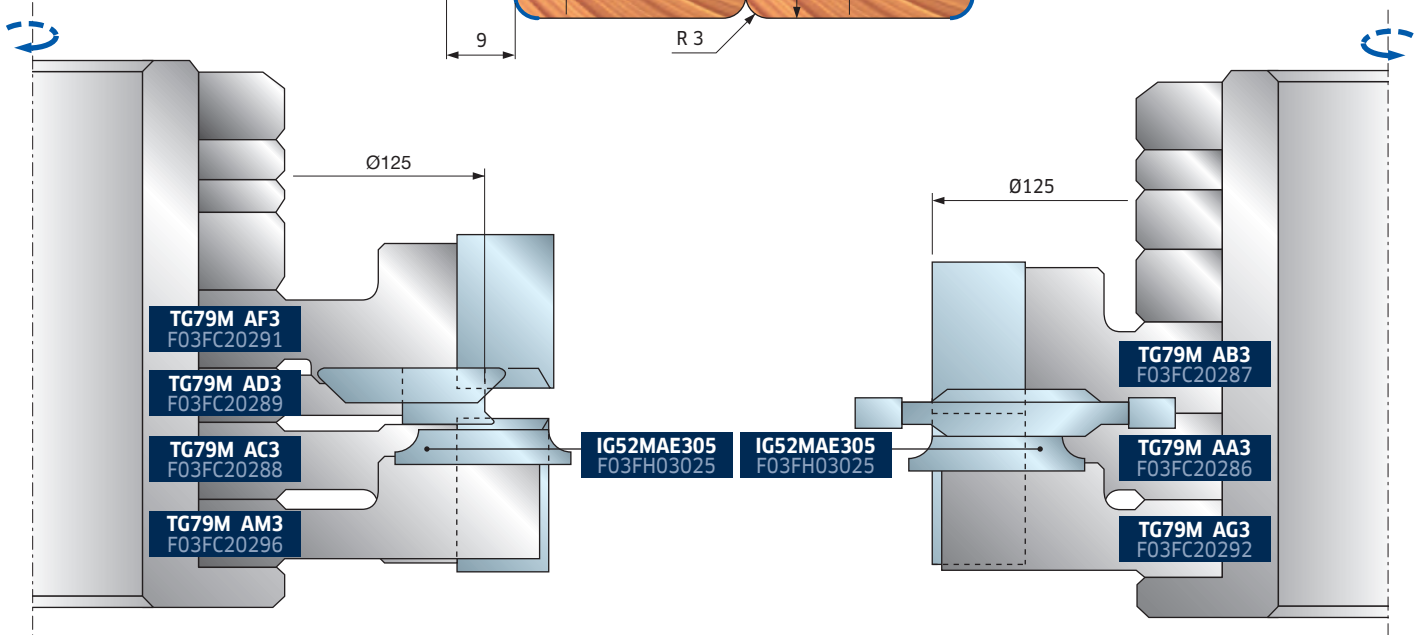

PROFILE / PROFILO 13

Cutterhead set / Gruppo
TG79MG 036

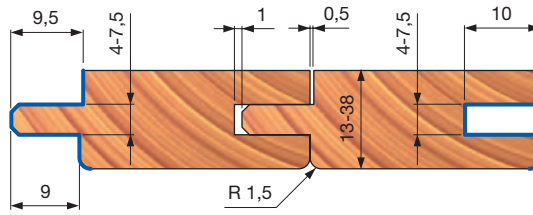
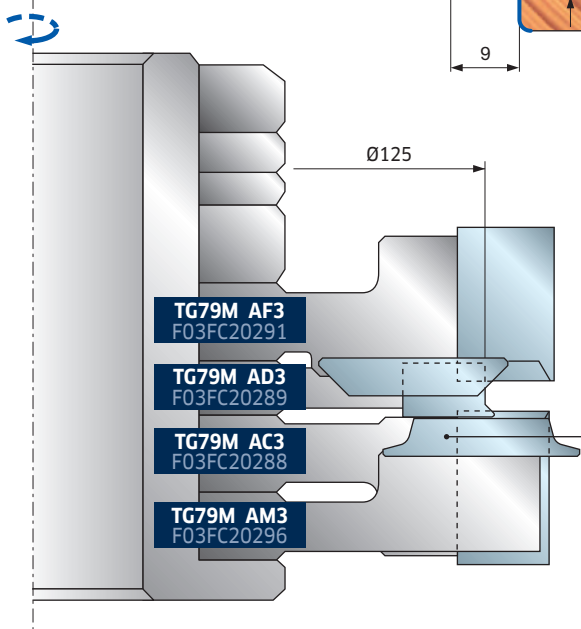

Cutterhead set / Gruppo
TG79MG 031

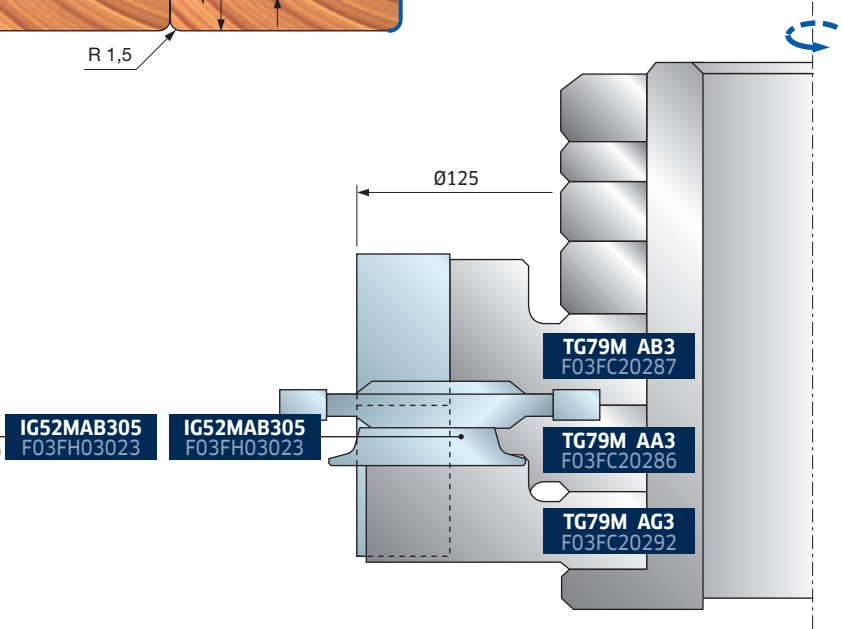

PROFILE / PROFILO 14

Cutterhead set / Gruppo
TG79MG 037

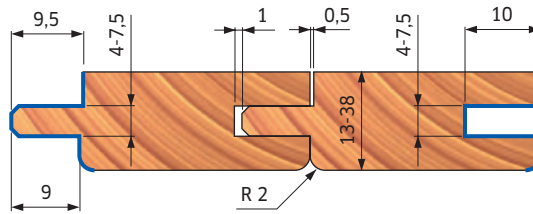
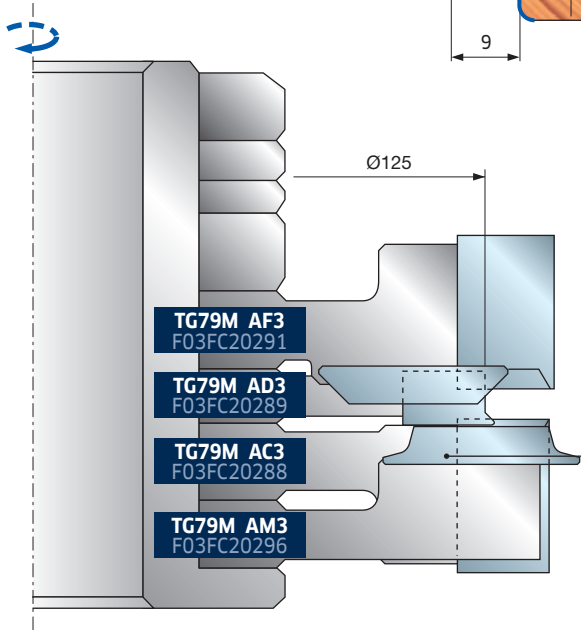

Cutterhead set / Gruppo
TG79MG 032

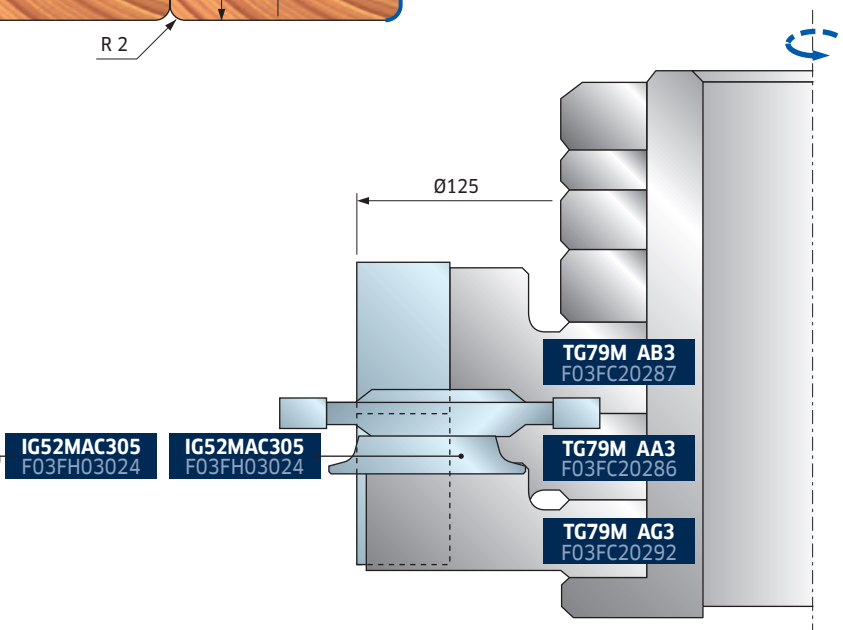

PROFILE / PROFILO 15

Cutterhead set / Gruppo
TG79MG 038

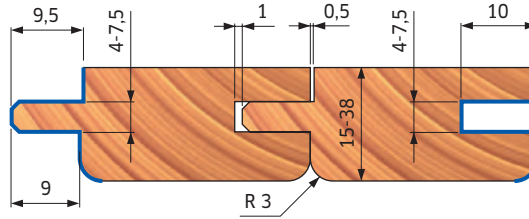

Cutterhead set / Gruppo
TG79MG 033

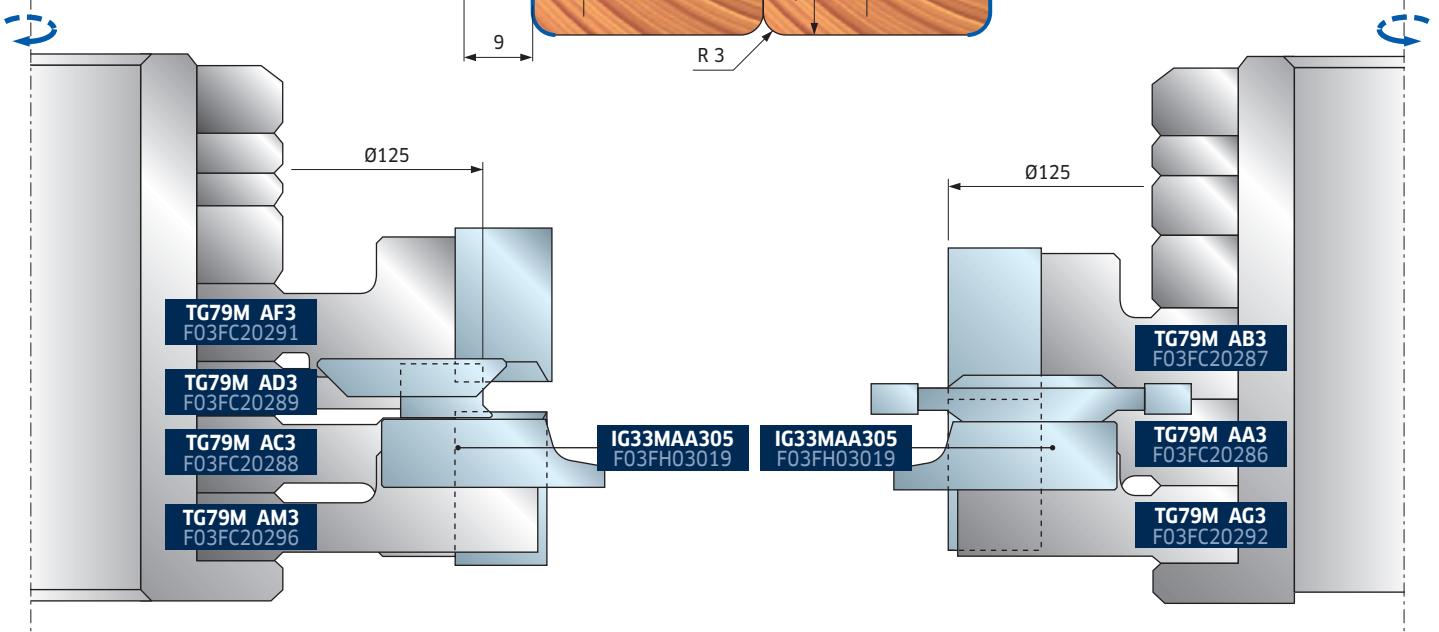

PROFILE / PROFILO 16

Cutterhead set / Gruppo
TG79MG 039

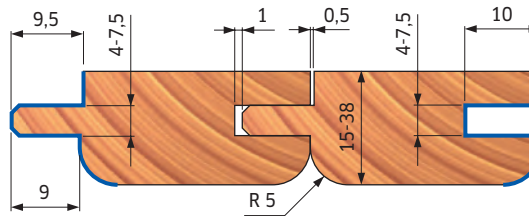

Cutterhead set / Gruppo
TG79MG 034

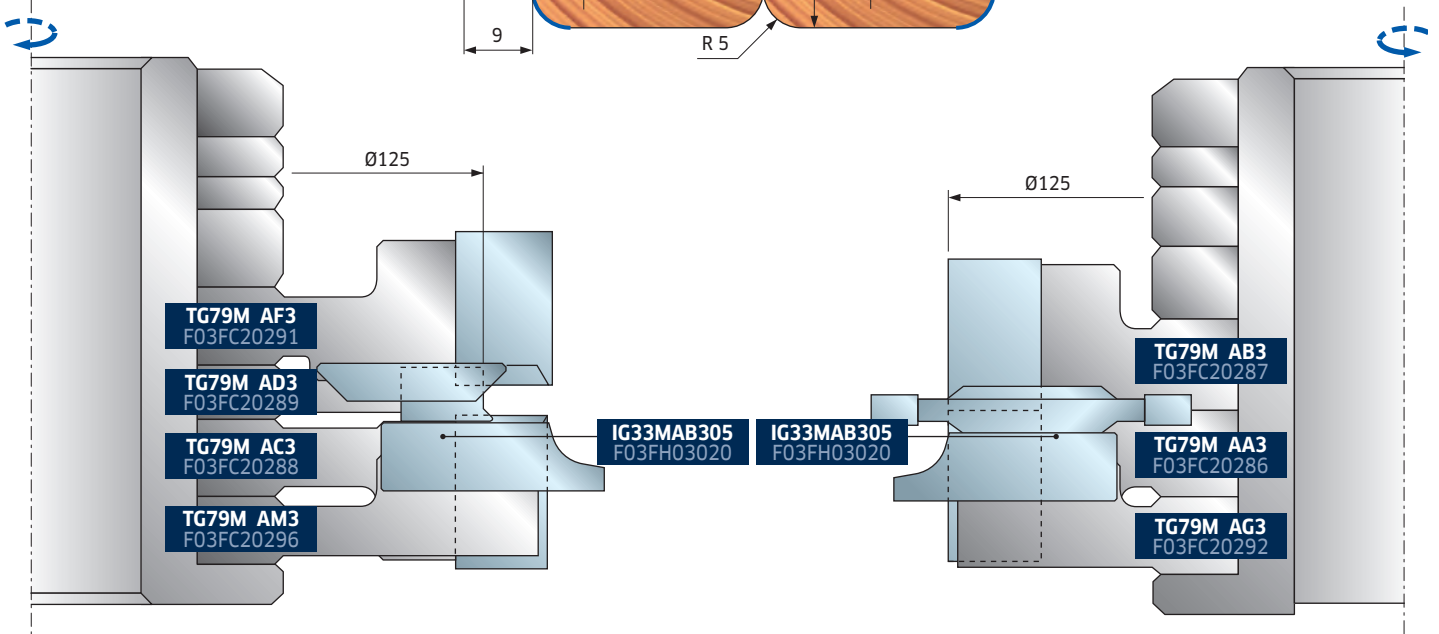

TG99MG Z = 4

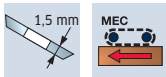

Chart for choosing spare parts
Tabella per la scelta dei ricambi

Code Codice	SAP SAP	For cutterheads TG99M Per teste TG99M
EA3 EB3 EC3 ED3 EE3 EF3 EG3 EH3 EI3 EK3 EL3		
CG26MBA310	F03FH02937	• • • •
CG26MDA310	F03FH02939	• • • •
CG26MEA310	F03FH02940	• • • •
CN03M BA9	F03FA00584	• • • •
CN03M BB9	F03FA00585	• • • •
CN09M AA9	F03FC01280	• • • •
CN09MD AD9	F03FC01300	• • • •
CN09MD A09	F03FC01306	• • • •
CN09MS AD9	F03FC01326	• • • •
VT05M AA9	F03FA04444	• • • •
VT16M AA9	F03FA04476	• • • •
VT16M AD9	F03FC20657	• • • •
VT16M AE9	F03FC20658	• • • •
VT19M AB9	F03FA04491	• • • •
VT19M BB9	F03FA04493	• • • •
VT19M MA9	F03FA04496	• • • •
VT20M AA9	F03FA04497	• • • •
VT20M MA9	F03FC20670	• • • •
VT20M NA9	F03FC20671	• • • •
IG04MSAA305	F03FH02994	• • • •
IG16MAA301	F03FC24161	• • • •
IG17MDAA305	F03FC24162	• • • •
IG51MBA305	F03FH03022	• • • •
IG52MAB305	F03FH03023	• • • •
RG02MAA305	F03FH03041	• • • •
SR06MSBB301	F03FC24201	• • • •
CB03M CA9	F03FA00165	• • • •
CB03M AA9	F03FA00162	• • • •
CB03M BA9	F03FA00163	• • • •

Sleeves for fence side spindle
Bussole per albero destro

Dimensions Dimensioni mm	Sleeve code Codice bussola	SAP
Ø50 x 110 x 30	BF10MD AA9	F03FC00616
Ø50 x 110 x 32	BF10MD AL9	F03FC24533
Ø50 x 110 x 35	BF10MD AB9	F03FC00617
Ø50 x 110 x 40	BF10MD AC9	F03FC00618

Sleeves for off side spindle
Bussole per albero sinistro

Dimensions Dimensioni mm	Sleeve code Codice bussola	SAP
Ø50 x 110 x 30	BF10MS AA9	F03FC00661
Ø50 x 110 x 32	BF10MS AL9	F03FC24538
Ø50 x 110 x 35	BF10MS AB9	F03FC00662
Ø50 x 110 x 40	BF10MS AC9	F03FC00663

DISTRIBUTER ZA SRBIJU

GATECH

Cutterheads sets for panelling and flooring Gruppi di teste per perline e parchetti

Profile Profilo	Tongue set Gruppo per maschio	SAP SAP	Groove set Gruppo per femmina	SAP SAP
A	TG99MG002	F03FC22132	TG99MG001	F03FC22131
B	TG99MG003	F03FC22133	TG99MG001	F03FC22131
C	TG99MG009	F03FC22140	TG99MG008	F03FC22139
D	TG99MG011	F03FC22142	TG99MG010	F03FC22141
E	TG99MG005	F03FC22135	TG99MG004	F03FC22134
F	TG99MG007	F03FC22137	TG99MG006	F03FC22136
G	TG99MG013	F03FC22145	TG99MG012	F03FC22143
H	TG99MG015	F03FC22146	TG99MG014	F03FC22144

Tools for TG99MG sets - Utensili per gruppi TG99MG

D mm	B mm	d mm	Z	R	Max RPM 1/min.	Code Codice	SAP SAP
125	30	50	4	4	10.300	TG99M EA3	F03FC22120
125	30	50	4	4	10.300	TG99M EB3	F03FC22121
137	30	50	4	8	9.600	TG99M EC3	F03FC22122
137	30	50	4	4	9.600	TG99M ED3	F03FC22123
138	20	50	4	4	9.600	TG99M EE3	F03FC22124
137	12	50	4	4	9.600	TG99M EF3	F03FC22125
125	30	50	4	6	10.300	TG99M EG3	F03FC22126
149	12	50	4	8	9.000	TG99M EH3	F03FC22127
143	20	50	4	4	9.000	TG99M EI3	F03FC22128
142	12	50	4	4	9.000	TG99M EK3	F03FC22129
169	12	50	4	8	8.300	TG99M EL3	F03FC22130

Spare parts Parti di ricambio	Dimensions Dimensioni mm	Code Codice	SAP SAP	
	Knife / Coltello	12x12x1,5	CG26MBA310	F03FH02937
	Wedge / Cuneo	15x10x8	CN09M AA9	F03FC01280
	Nut / Ogiva	10x11,5x6	VT20M AA9	F03FA04497
	Screw / Vite	M6x22	VT19M AB9	F03FA04491
	Knife / Coltello	20x12x1,5	CG26MDA310	F03FH02939
	Wedge / Cuneo	15x16x8	CN09MD A09	F03FC01306
	Screw / Vite	M10x22	VT19M MA9	F03FA04496
	Nut / Ogiva	15x13,3x10	VT20M MA9	F03FC20670
	Knife / Coltello	30x12x1,5	CG26MEA310	F03FH02940
	Wedge / Cuneo	15x26x8	CN09MD AD9	F03FC01300
	Wedge / Cuneo	15x26x8	CN09MS AD9	F03FC01326
	Nut / Ogiva	15x13,3x10	VT20M NA9	F03FC20671
	Nut / Ogiva	15x13,3x10	VT20M MA9	F03FC20670
	Screw / Vite	M10x22	VT19M MA9	F03FA04496
	Wedge / Cuneo	28x9,5x8	CN03M BB9	F03FA00585
	Screw / Vite	M8x22	VT19M BB9	F03FA04493
	Wedge / Cuneo	14x21,5x22	CN03M BA9	F03FA00584
	Spur / Rasante	22,86x2,5	RG02MAA305	F03FH03041
	Screw / Vite	M5x8	VT05M AA9	F03FA04444
	Spur insert / Inserto rasante	34x9x16	SR06MSBB301	F03FC24201
	Screw / Vite	M6x13	VT16M AE9	F03FC20658
	Beveled grooves ins. / Ins. incastrati smuss.	32,7x16x8,5	IG16MAA301	F03FC24161
	Screw / Vite	M6x15,5	VT16M AD9	F03FC20657
	Grooving insert / Inserto per incastrati	40x16x4	IG04MSAA305	F03FH02994
	Beveled insert / Inserto smussato	35x4x7	IG17MDAA305	F03FC24162
	Beveled insert / Inserto smussato	22x16x5 45°	IG51MBA305	F03FH03022
	Rounding insert / Inserto raggiatore	22x16x5 R=1,5	IG52MAB305	F03FH03023
	Screw / Vite	M6x14,5	VT16M AA9	F03FA04476
	Torx key / Chiave Torx	T9	CB03M CA9	F03FA00165
	Allen key / Chiave	3 x 110	CB03M AA9	F03FA00162
	Allen key / Chiave	4 x 110	CB03M BA9	F03FA00163

The above codes are intended without sleeve, which should be ordered separately.

I codici delle tabelle relative ai gruppi sono da considerarsi esclusa la bussola, la quale andrà ordinata a parte.

PROFILE / PROFILO A

Cutterhead set / Gruppo
TG99MG002

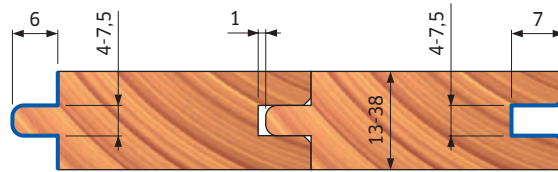
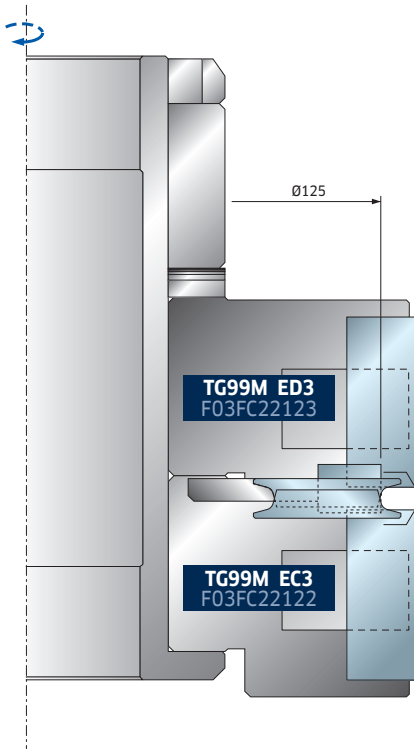

Cutterhead set / Gruppo
TG99MG001

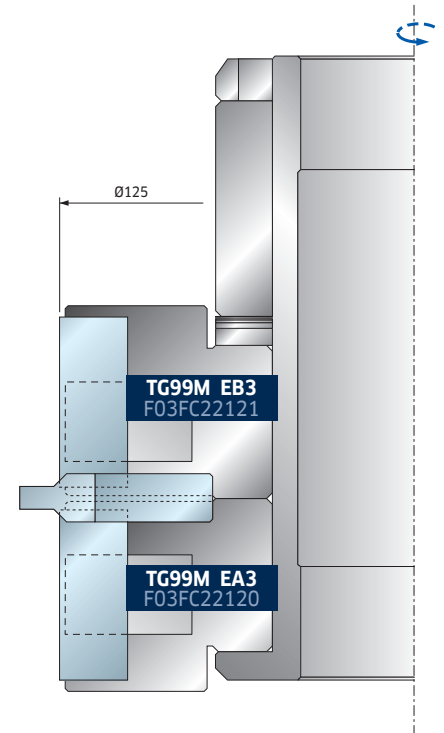

PROFILE / PROFILO B

Cutterhead set / Gruppo
TG99MG003

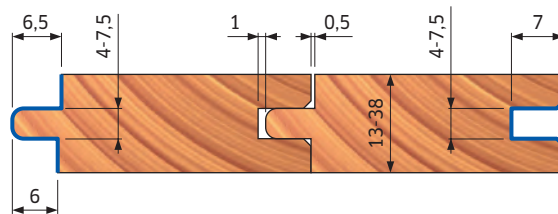
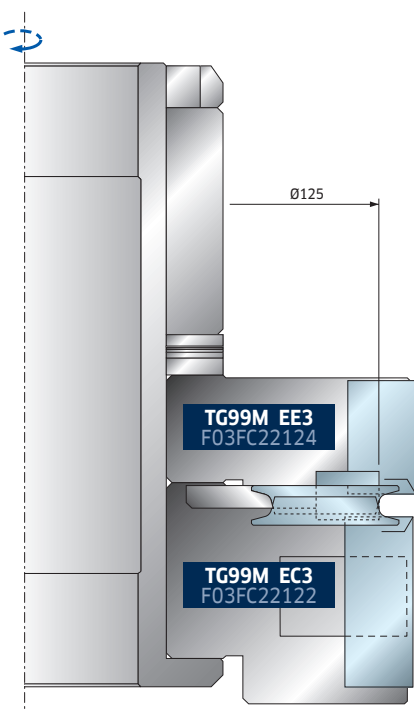

Cutterhead set / Gruppo
TG99MG001

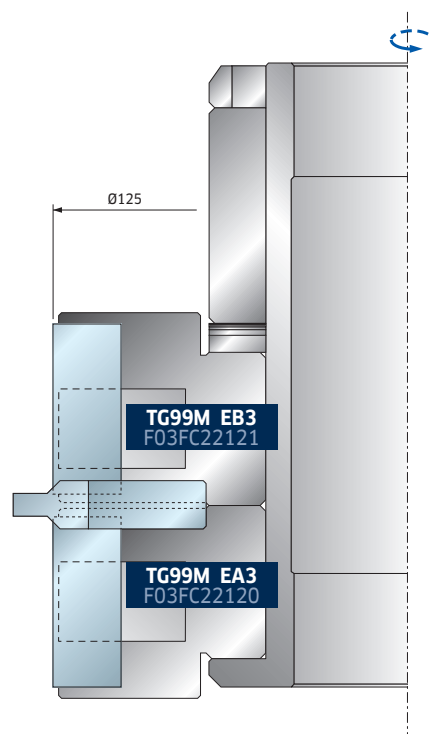

PROFILE / PROFILO C

Cutterhead set / Gruppo
TG99MG009

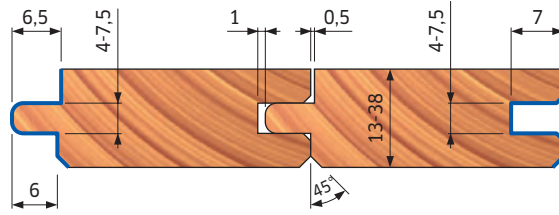
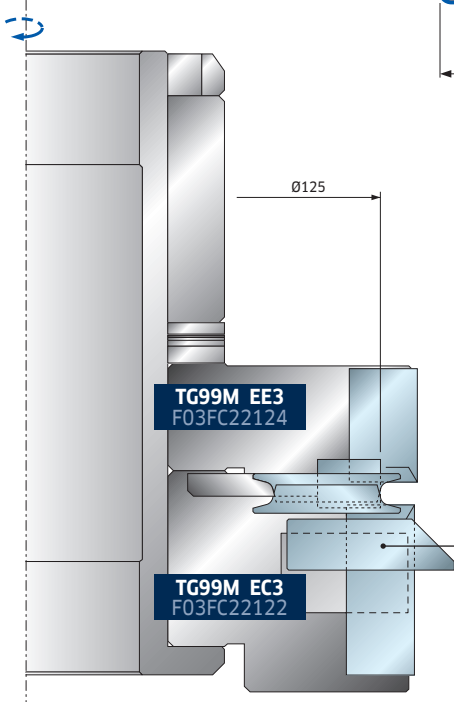

Cutterhead set / Gruppo
TG99MG008

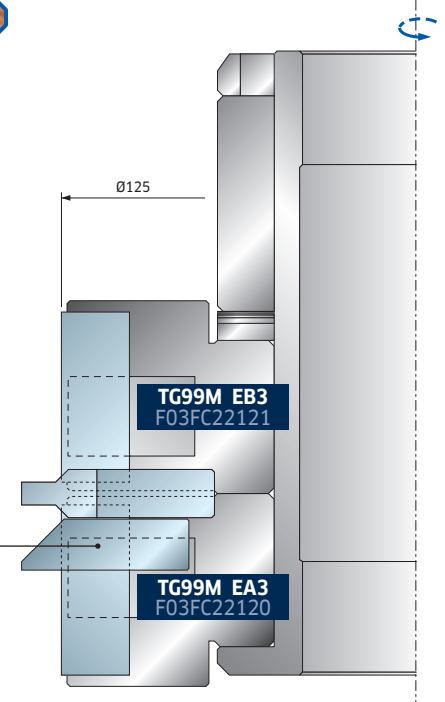

PROFILE / PROFILO D

Cutterhead set / Gruppo
TG99MG011

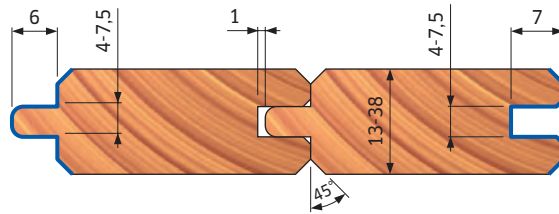
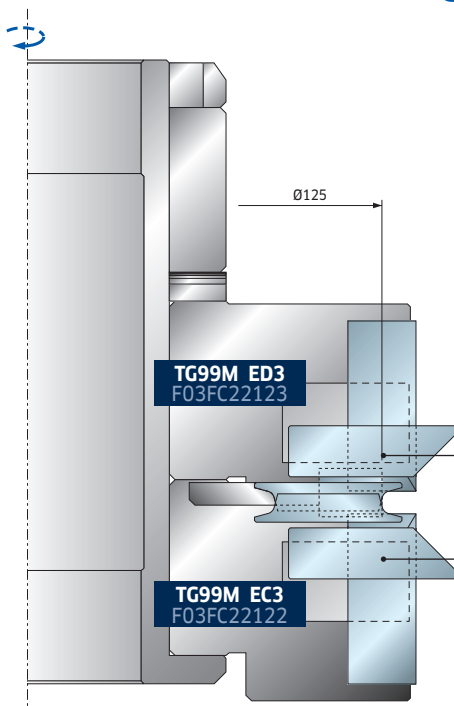

Cutterhead set / Gruppo
TG99MG010

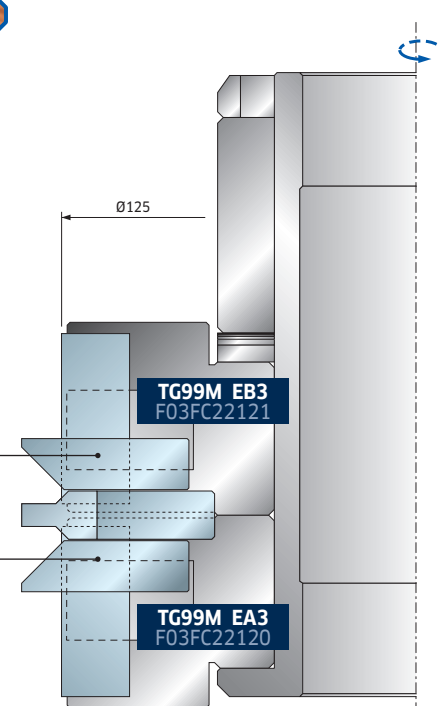

PROFILE / PROFILO E

Cutterhead set / Gruppo
TG99MG005

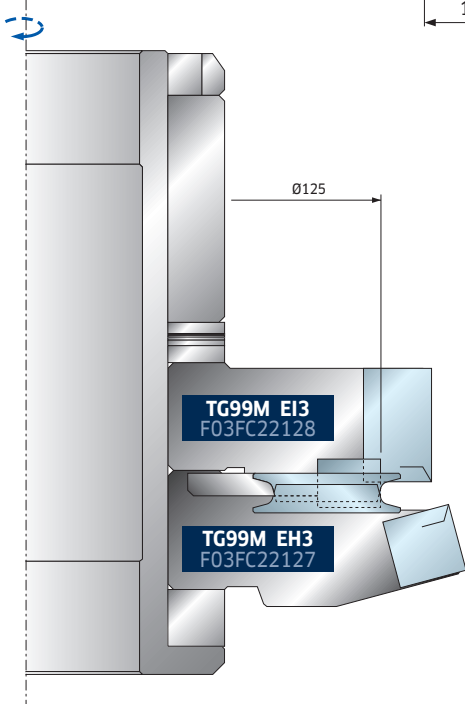
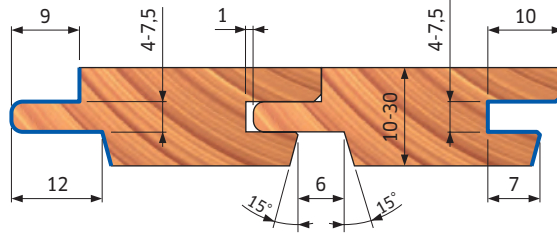

Cutterhead set / Gruppo
TG99MG004

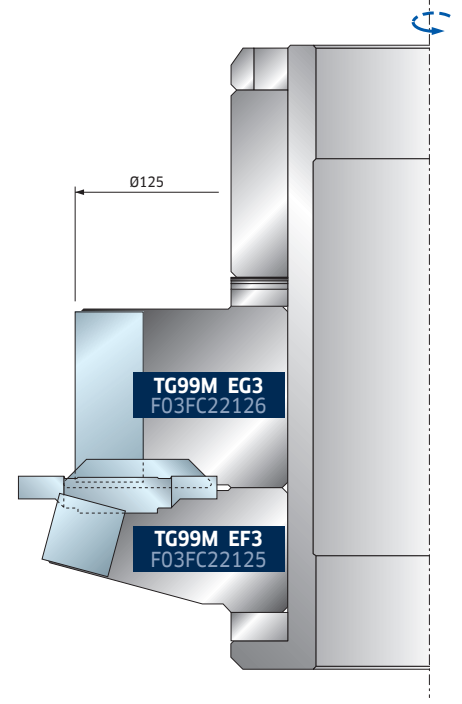

PROFILE / PROFILO F

Cutterhead set / Gruppo
TG99MG007

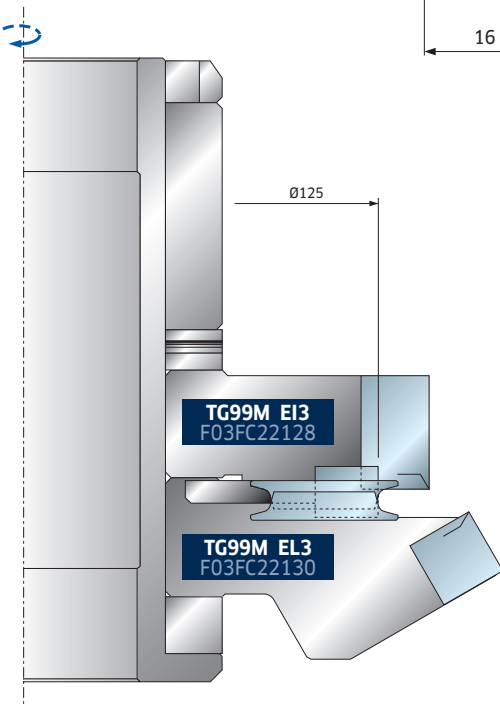
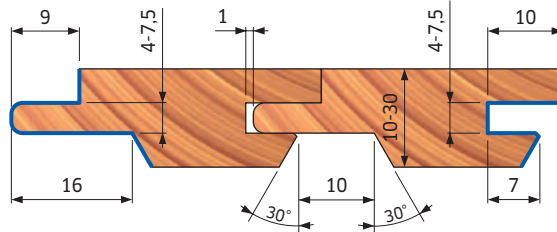

Cutterhead set / Gruppo
TG99MG006

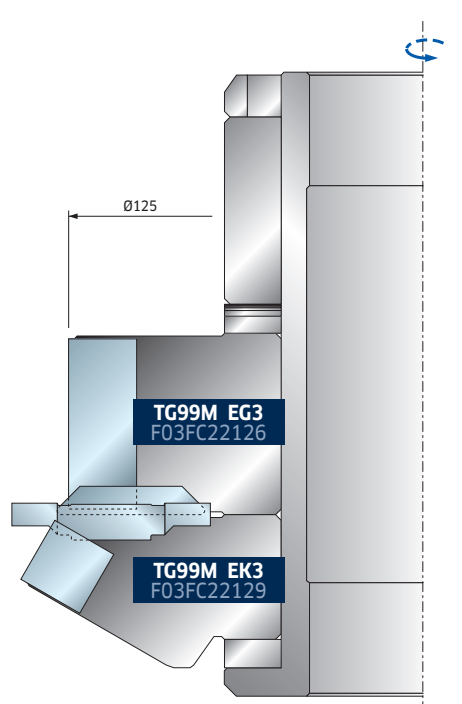

PROFILE / PROFILO G

Cutterhead set / Gruppo
TG99MG013

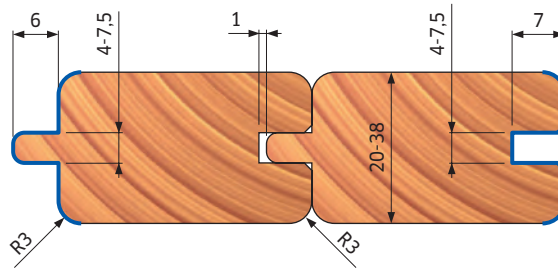

Cutterhead set / Gruppo
TG99MG012

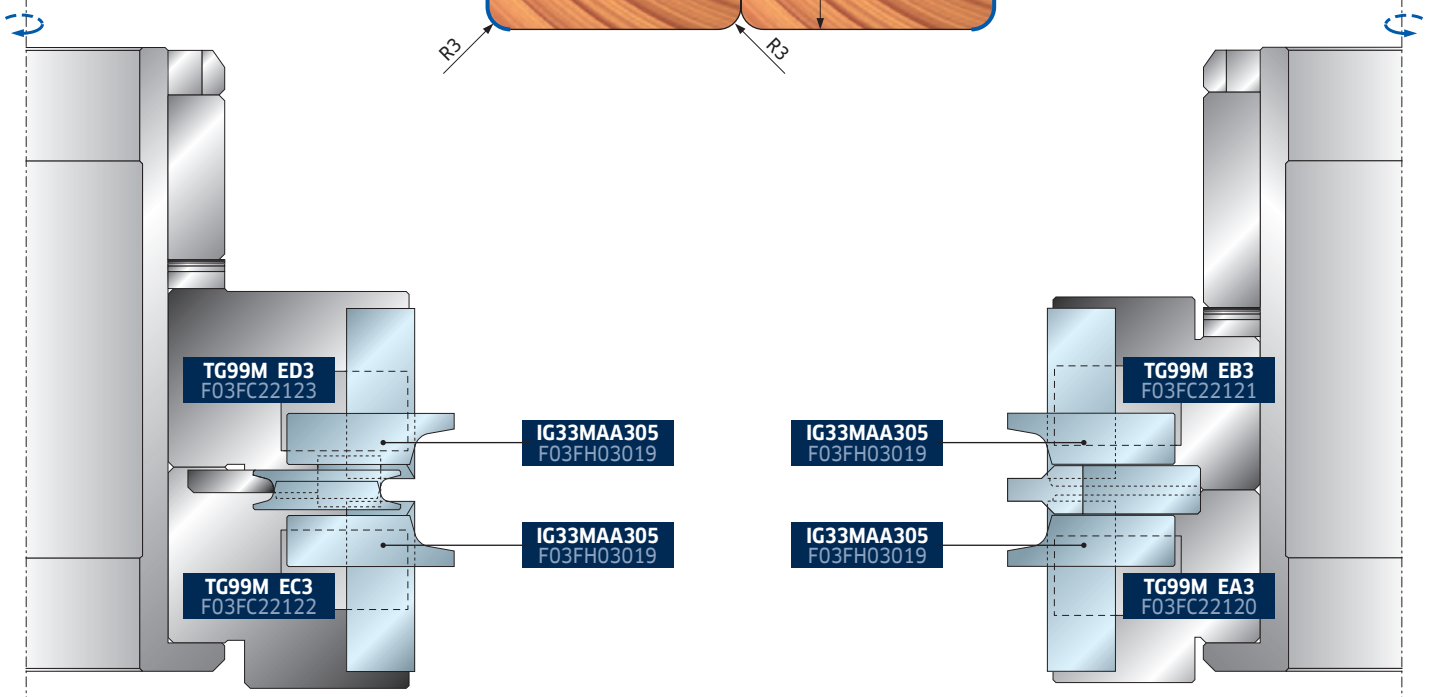

PROFILE / PROFILO H

Cutterhead set / Gruppo
TG99MG015

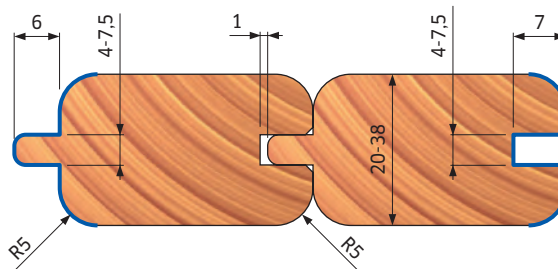

Cutterhead set / Gruppo
TG99MG014

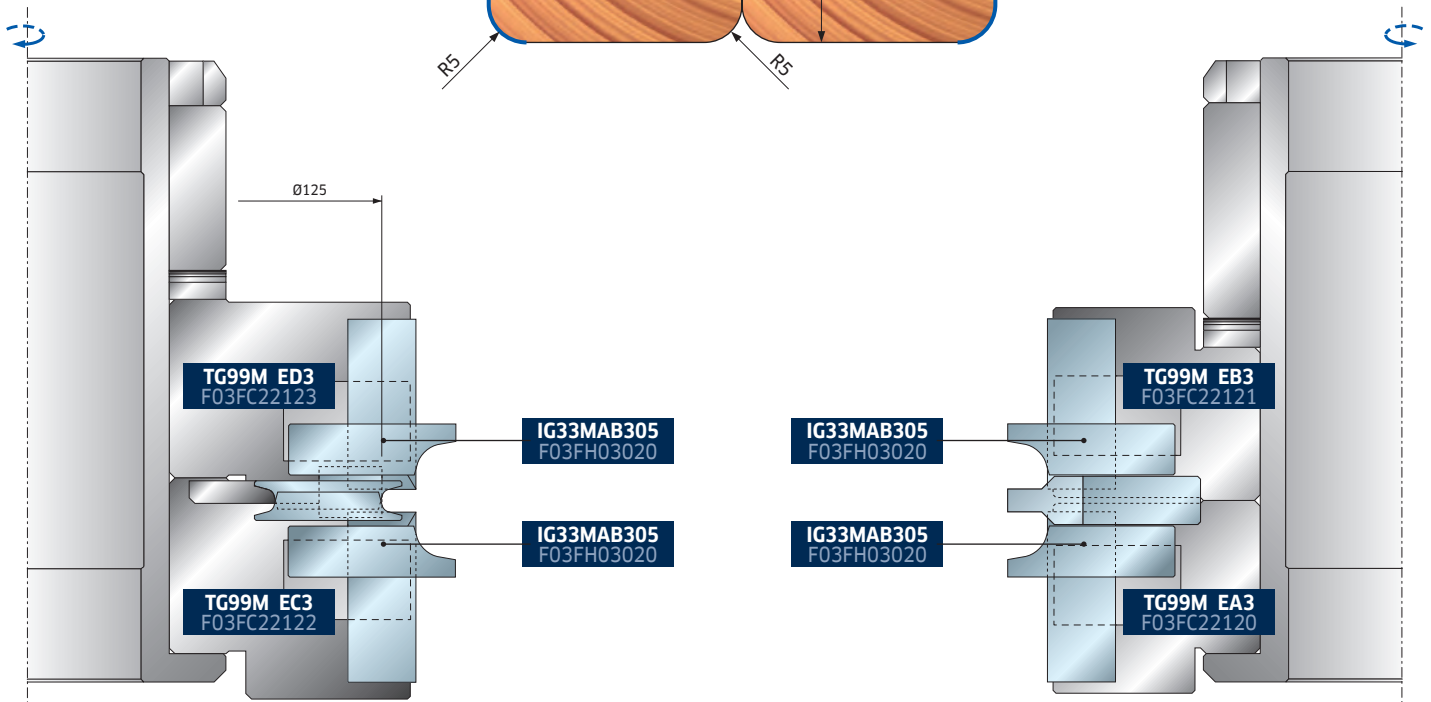

freud.

freud S.p.A.
Società Unipersonale
Via Padova, 3
33010 Tavagnacco (UD) IT
Tél. +39 0432 551411
Fax +39 0432 551440
info@freud.it
www.freud.it

DISTRIBUTER ZA SRBIJU

GATECH

DUČEVAC 15 - 11260 UMKA - SRBIJA

☎ 011/802-70-70 ✉ info@gatech.rs

www.gatech.rs